

# L2ight: Enabling On-Chip Learning for Optical Neural Networks via Efficient in-situ Subspace Optimization

Jiaqi Gu, Hanqing Zhu,  
Chenghao Feng, Zixuan Jiang,  
Ray T. Chen, David Z. Pan

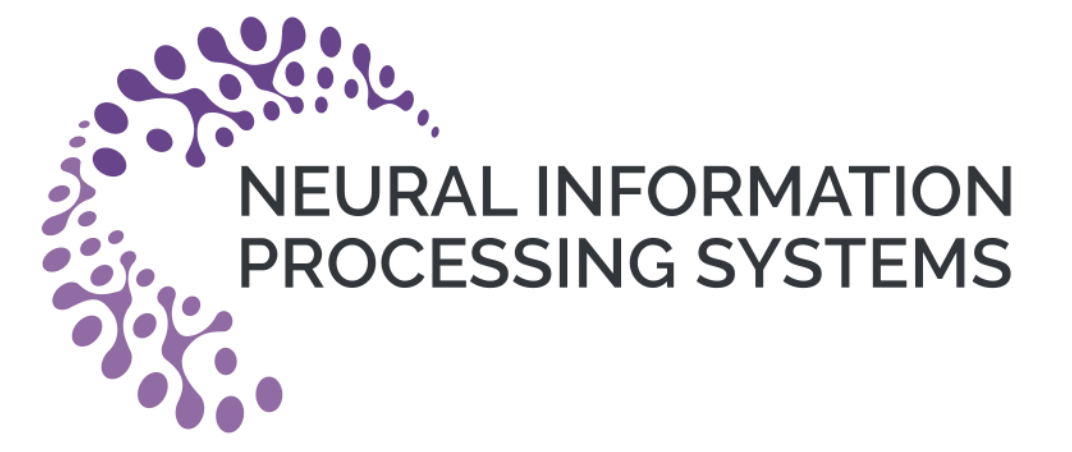

## Introduction: Optical Neurocomputing

Photonics for AI Acceleration: **Ultra-Fast & Ultra-Efficient**

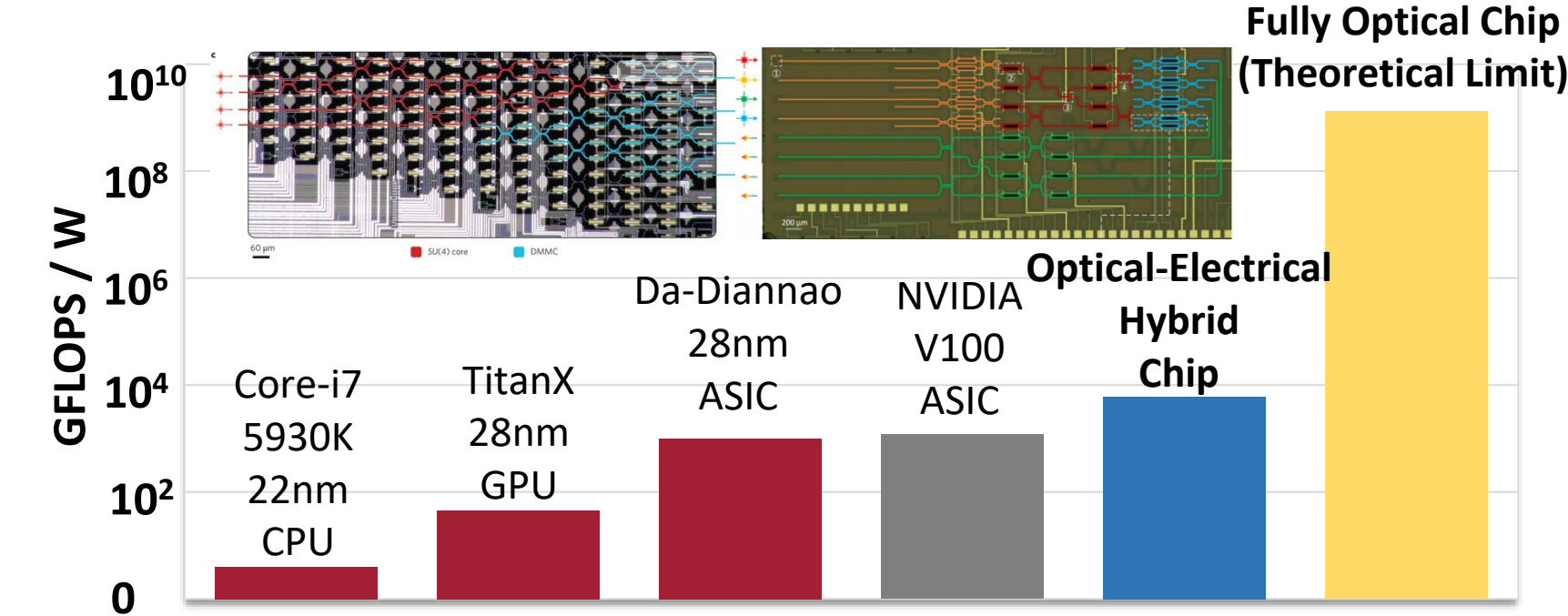

### Optical Neural Network Basics

- Singular value decomposition
- Map unitary matrix to MZI arrays

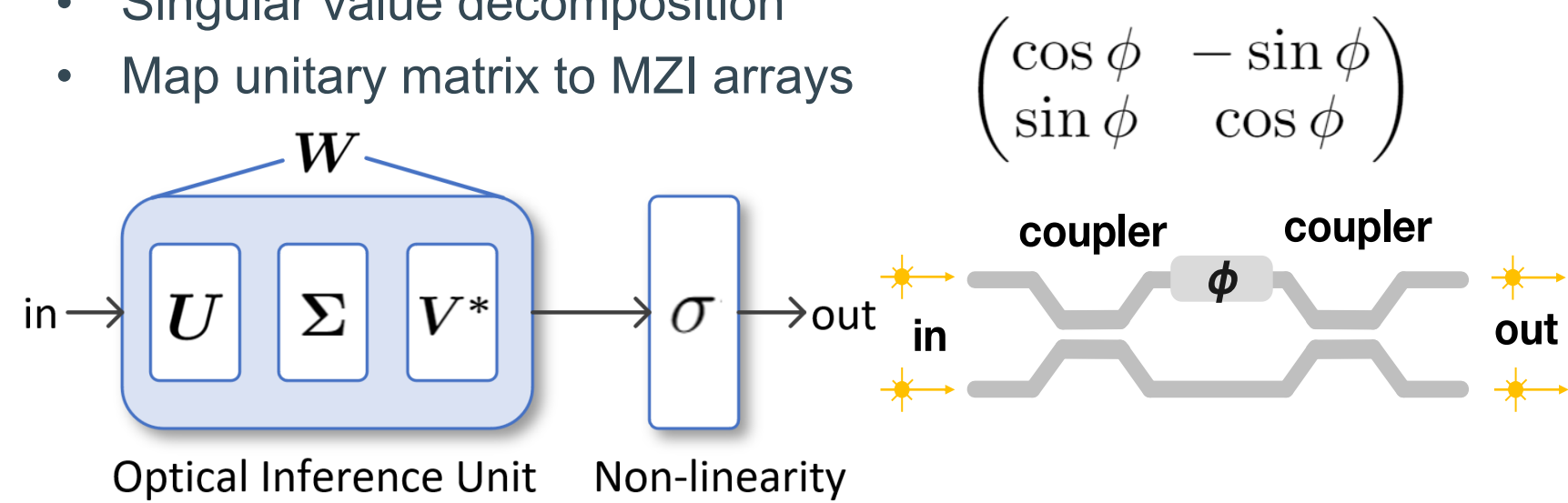

### ONN On-Chip Training

- Robust** Deployment & On-Chip **Learnability**
- Ultra-fast** & effective **in-situ noise** handling

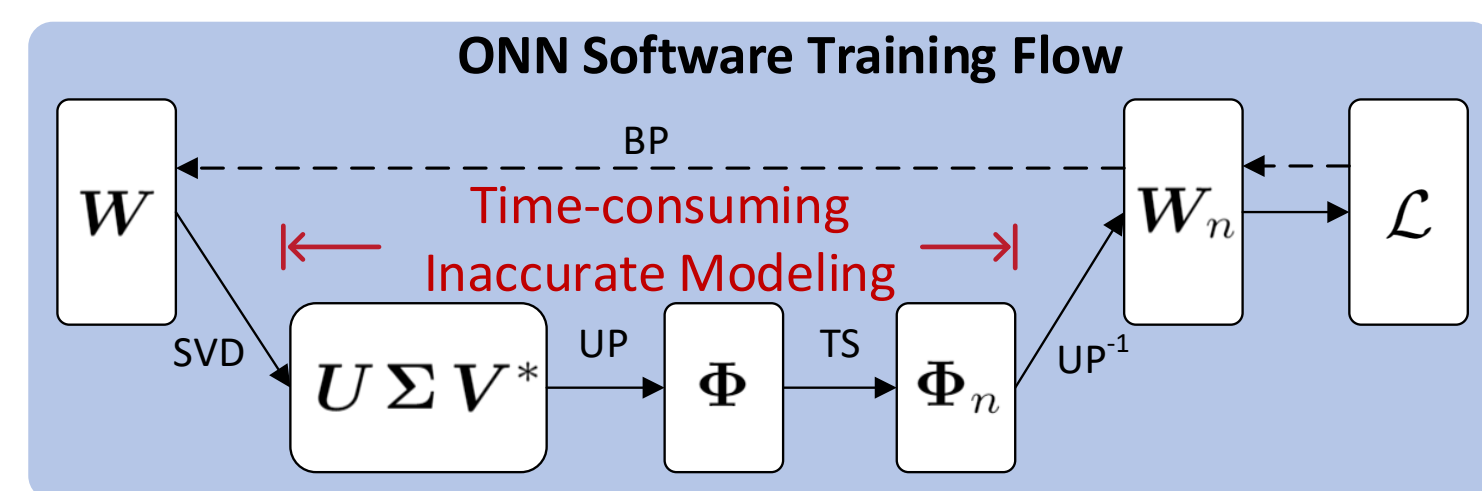

### Challenges and Prior Work

- Unscalable: 100 ~ 1000 MZIs
- Inefficient & unstable

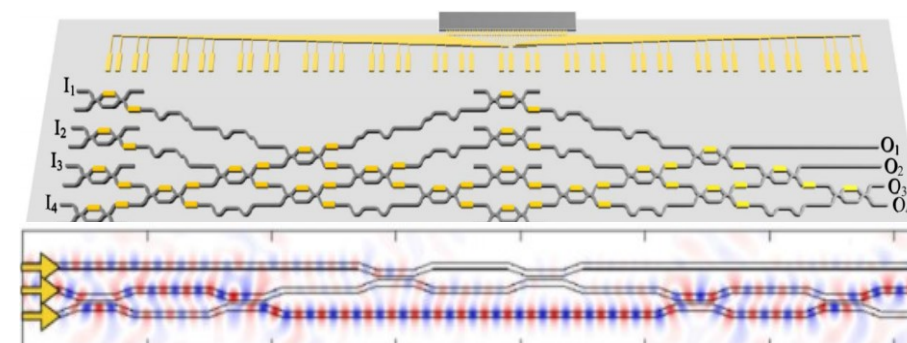

	PSO [OE'19]	AVM [Optica'18]	FLOPS [DAC'20]	MixedTrain [AAAI'21]	<b>Our L<sup>2</sup>ight</b>
#Params	~100	~100	~1,000	~2,500	~10 M
Algorithm	Evolution (ZO)	Adjoint Method (FO)	ZO SGD	SZO-SCD	<b>ZO + FO</b>
Resolution Req.	High	Medium	High	Medium	<b>Medium</b>
Observability Req.	Coh. I/O	Coh. I/O+ Per device monitor	Coh. I/O	Coh. I/O	<b>Coh. I/O</b>

## L<sup>2</sup>ight: Our Synergistic On-Chip Learning Framework

- Scalability:** First to handle **million-parameter** ONNs
- Efficiency:** Multi-level sparsity for **30×** higher efficiency

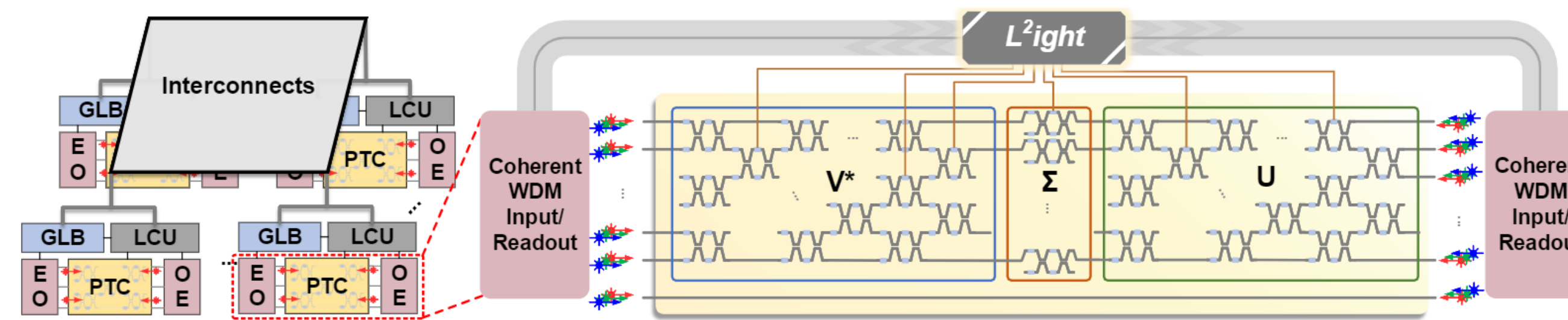

### Three-stage Framework

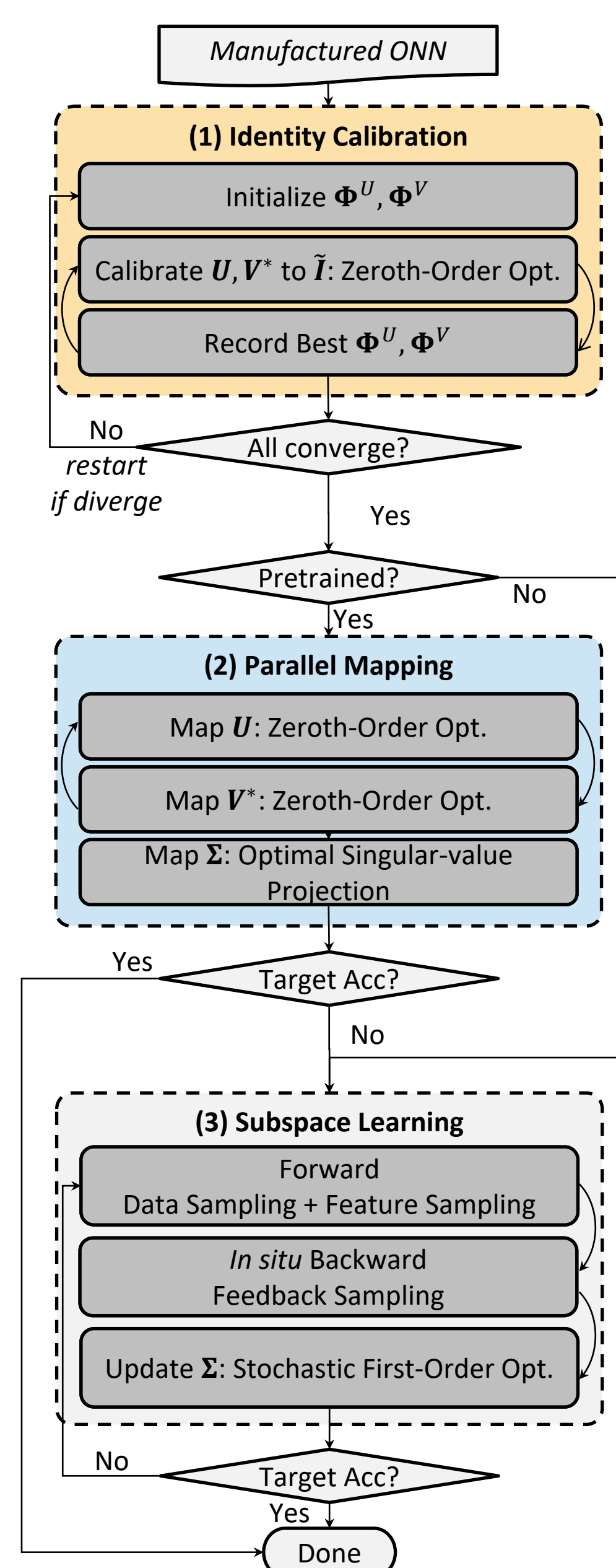

### Identity Calibration (IC)

- Variation-Agnostic Circuit State Preparation
- Large-scale ZOO** → **Batched subtasks**

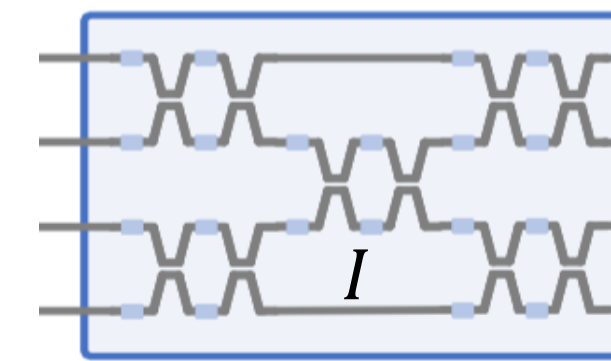

### Parallel Mapping (PM)

- Decouple ZOO from stochasticity** → **Efficient mapping**

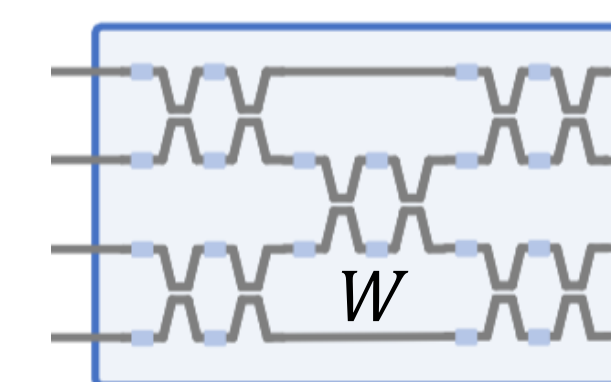

### Subspace Learning (SL): Only optimize singular values

- First-order** subspace gradient via **Reciprocity**
- Trade full-space trainability** → **Efficient first-order gradients**

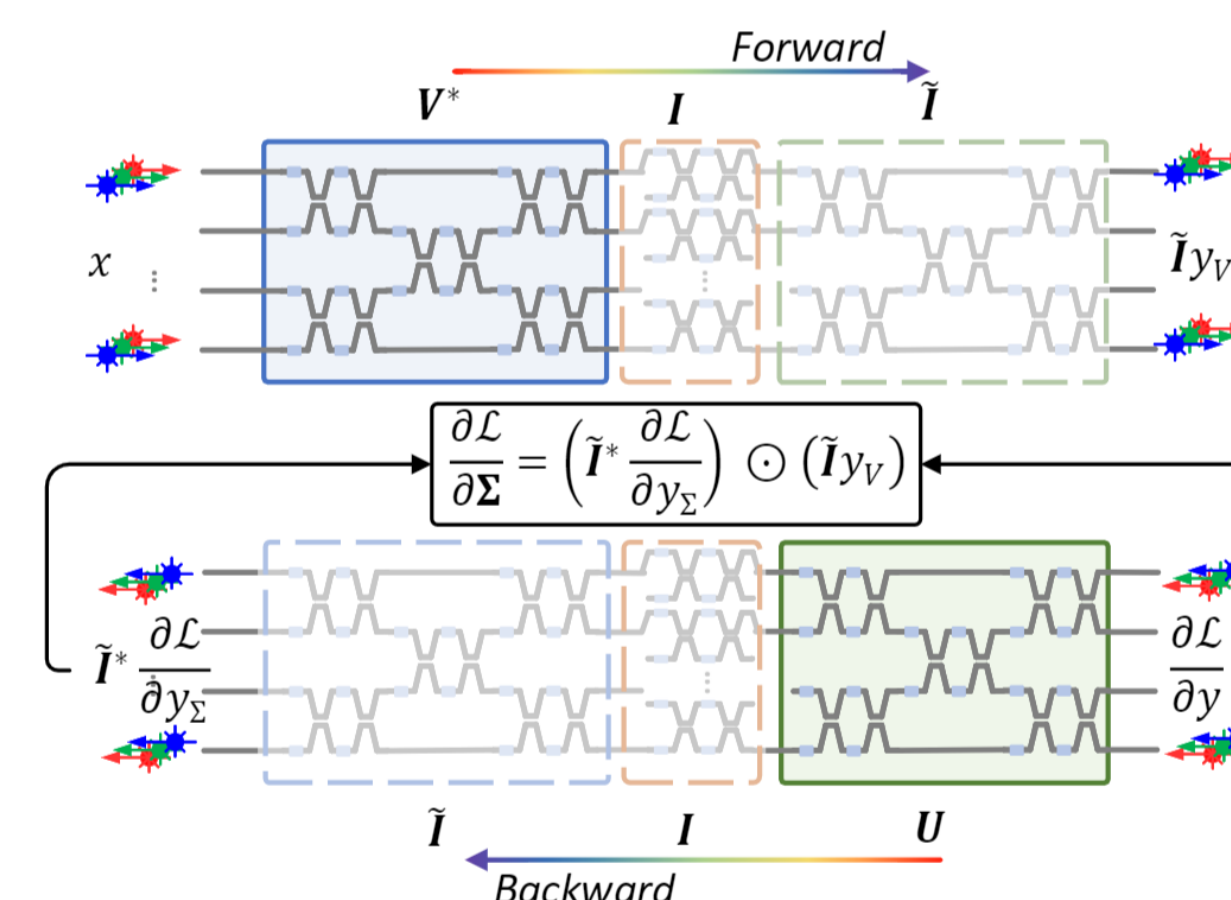

### Efficient Multi-level Sparse Subspace Learning

#### Sampling feedback matrix

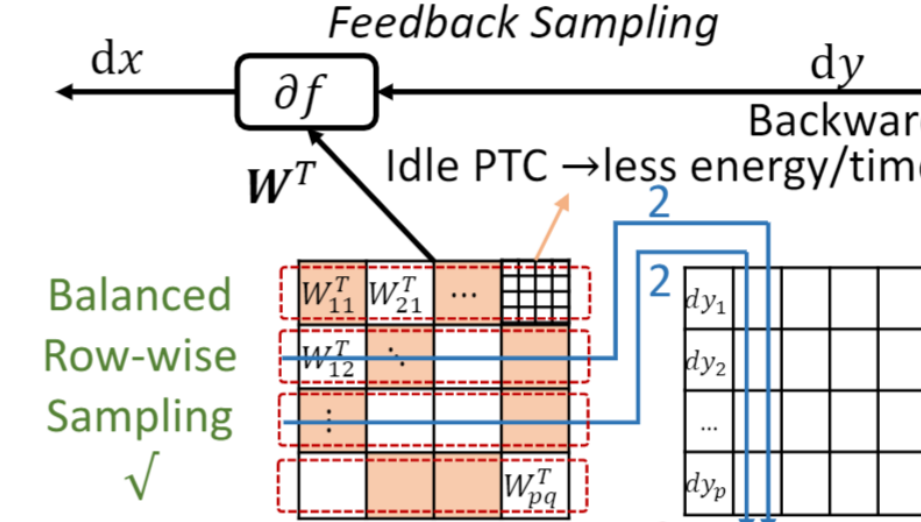

#### Sampling unrolled feature maps

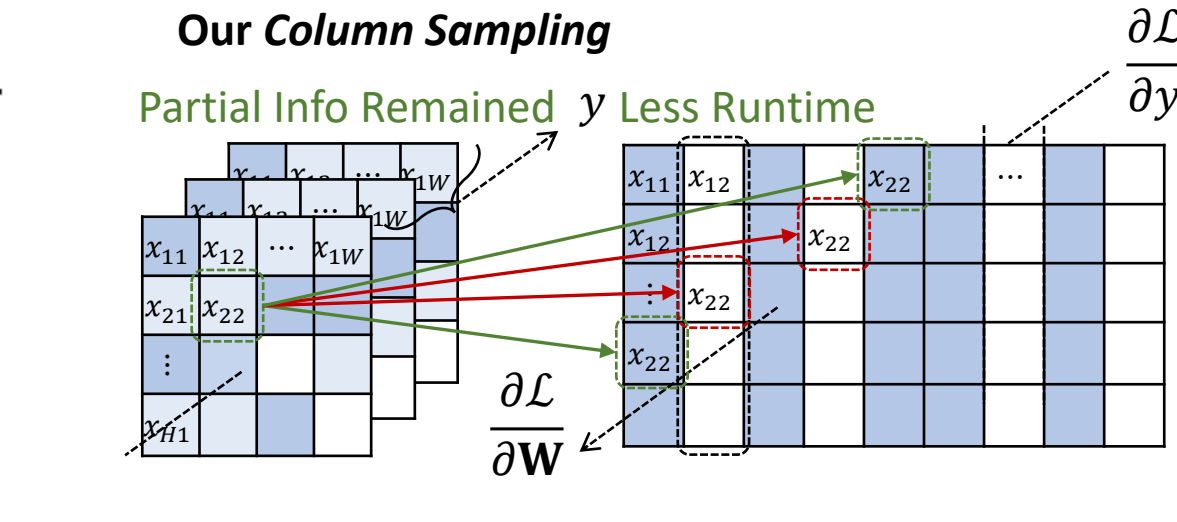

## Experimental Results: Scalability & Efficiency

### 1000× more scalable: million-parameter ONNs

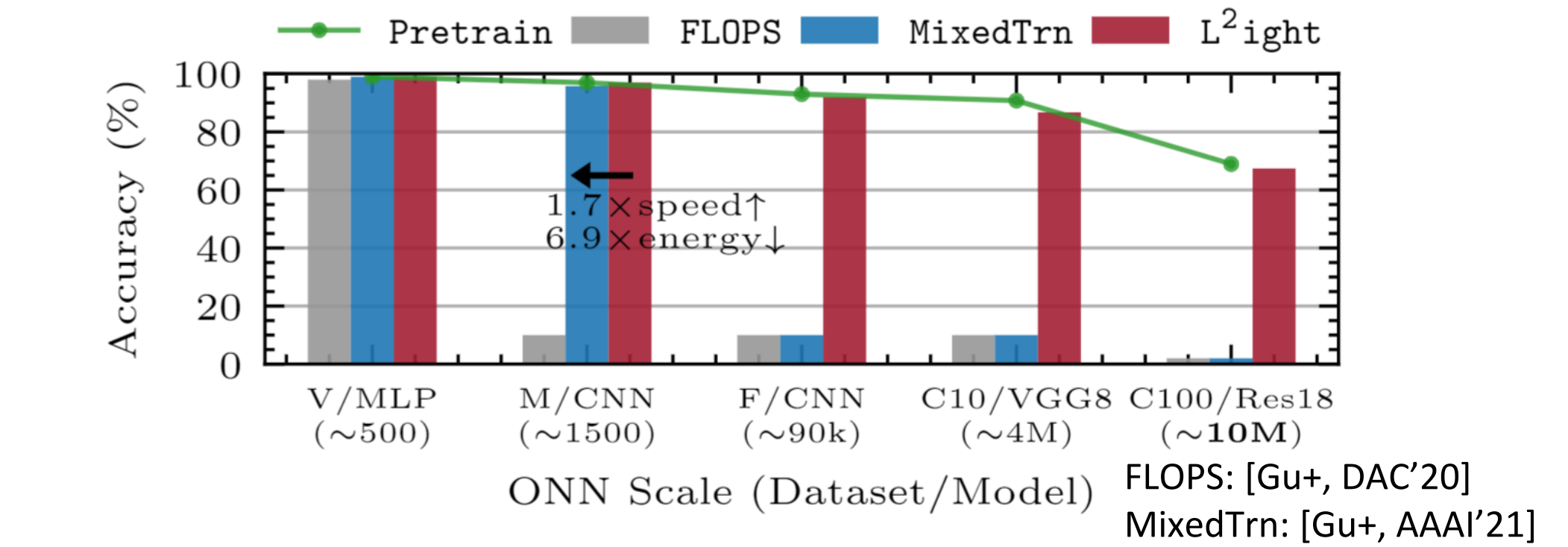

### 30× more energy-efficient + self-learnability and transferability

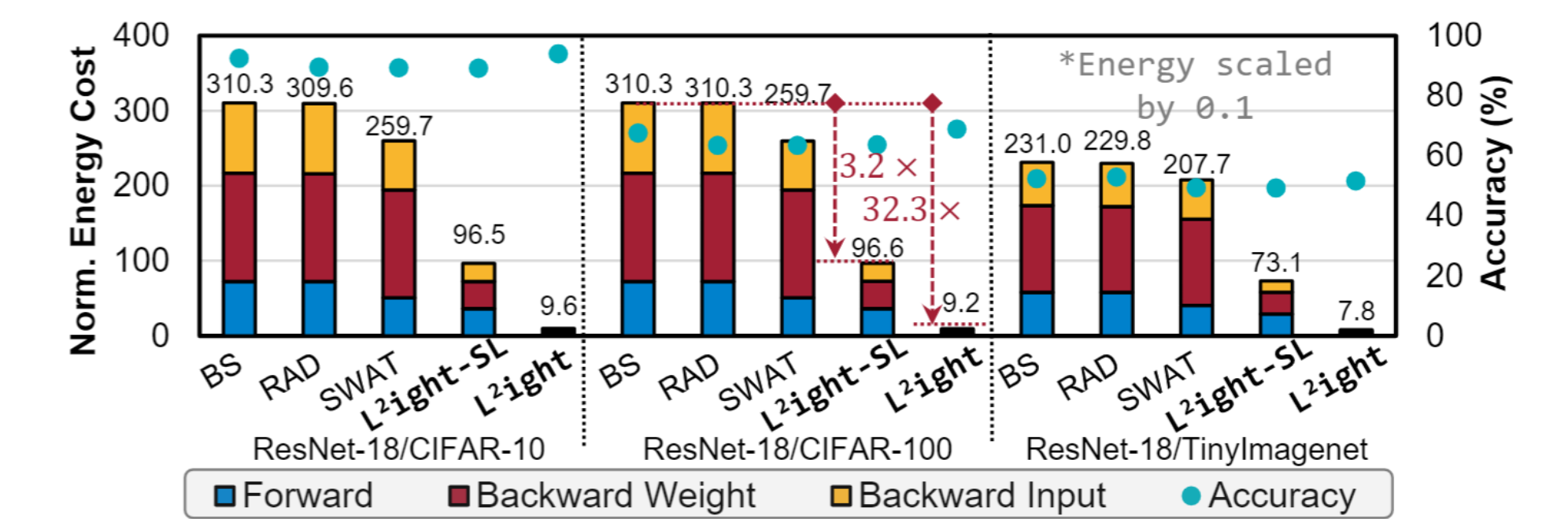

## Future Work

ONN chip tape-out, measurement, and on-chip training deployment

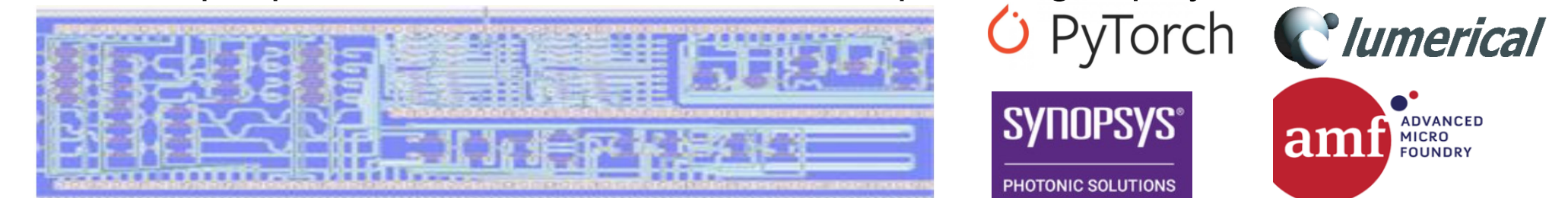

### References

- Jiaqi Gu, Zheng Zhao, et al. (2020). "FLOPS: Efficient On-Chip Learning for Optical Neural Networks Through Stochastic Zeroth-Order Optimization." In: DAC.
- Jiaqi Gu, Chenghao Feng, et al. (2021). "Efficient on-chip learning for optical neural networks through power-aware sparse zeroth-order optimization." In: AAAI.
- Yichen Shen, Nicholas C. Harris, et al. (2017). "Deep learning with coherent nanophotonic circuits." In: Nature Photonics.

Website: <https://jeremielomelo.github.io>

Open-source: <https://github.com/JeremieMelo/L2ight>

PyTorch-ONN Library: <https://github.com/JeremieMelo/pytorch-onn>

